

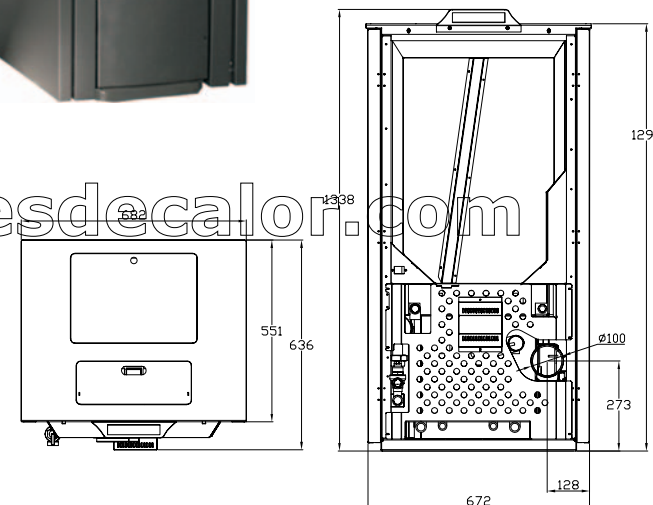

ANTRACITA 



<http://www.lojadosrecuperadoresdec calor.com>

## CANTINA SUPER AGUA



Potencia / Potenza / Potência / Puissance / Power: 29 kw  
Rendimento / Rendimento / Rendement / Efficiency: 91 %  
Tolva / Tramoggia / Tolva / Reservoir / Tank: 60 kg  
Consumo / Consommation / Consumption: 1400-6200 gr/h  
Peso / Peso / Peso / Poids / Weight: 215 kg  
Medidas / Misuri / Dimension / Measures: 682x636x1294 mm