

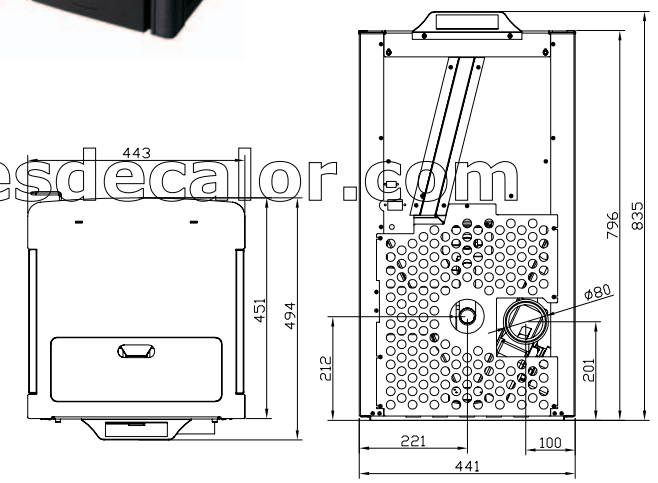

- INOXIDABLE
- ANTRACITA

<http://www.lojadosrecuperadoresdecador.com>



VENUS AIRE

- Potencia / Potenza / Potència / Puissance / Power: 5 kw-7 kw
- Rendimiento / Rendimento / Rendement / Efficiency: 87%
- Tolva / Tramoggia / Tolva / Reservoir / Tank: 13 kg
- Consumo / Consommation / Consumption: 500-1200 / 500-1600 gr/h
- Peso / Peso / Peso / Poids / Weight: 78 kg
- Medidas / Misuri / Dimension / Measures: 443x451x796 mm